

GENERAL INFORMATION

Project Name: _____

STANDARD NSF LISTED FINISH OPTIONS

- Brushed Aluminum Chrome
- Gloss Black Wrinkle Black
- Smoked Copper Polished Brass Finish
- Other _____

GLASS THICKNESS

- 1/4" Tempered Glass (not for shelves)
Centerline Max 54"
- 3/8" Tempered Glass (for shelf or span more
than 54") Centerline Max 66"
- 1/2" Tempered Glass (for shelf or span more than
66") Centerline Max 72"

GLASS CORNERS

- 1" Radius Corner (standard)
- Square Corners

LIGHT OPTIONS

- 2580 Slimline LED Light
- 790 Stealth Warmer
- 705 Stealth Light & Warmer
- 500 Stealth Heat/Light/Heat Combo

All BSI light and warmer units are UL Listed. See light spec sheets for detailed information. Also available with other manufacturers' light units. Contact BSI for details.

INSTALLATION OPTIONS

Above Counter: Stainless Steel Counter

Under Counter: Stainless Steel Counter

(Requires Under Counter Reinforcement & Access)

Above-Counter: Millwork Counter

Under-Counter: Millwork Counter

SS1: EZ Mount 2" x 8" Flange

SSU3-H: Heavy-Duty Flange

SSU3-N: Narrow Flange

SSU5-H: Heavy-Duty Flange

SSU5-N: Narrow Flange

MW1: Heavy-Duty Flange

MW2: Narrow Flange

MWU3: Narrow Flange

MWU4: Compression Installation
(not recommended for solid surfaces)

MWU5: Heavy-Duty Flange

ZG9930-5

Two-Tier Display Case

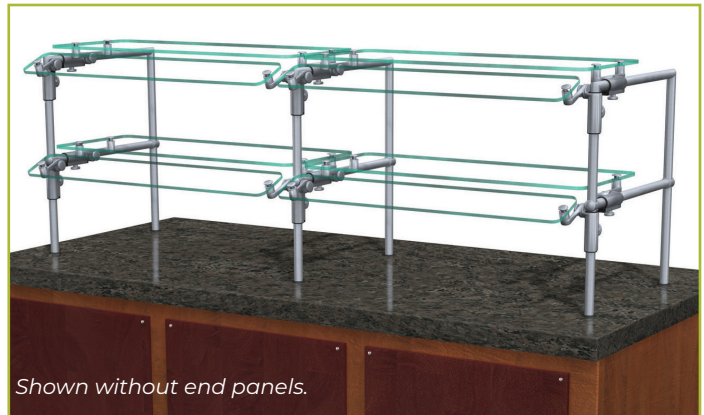

Shown without end panels.

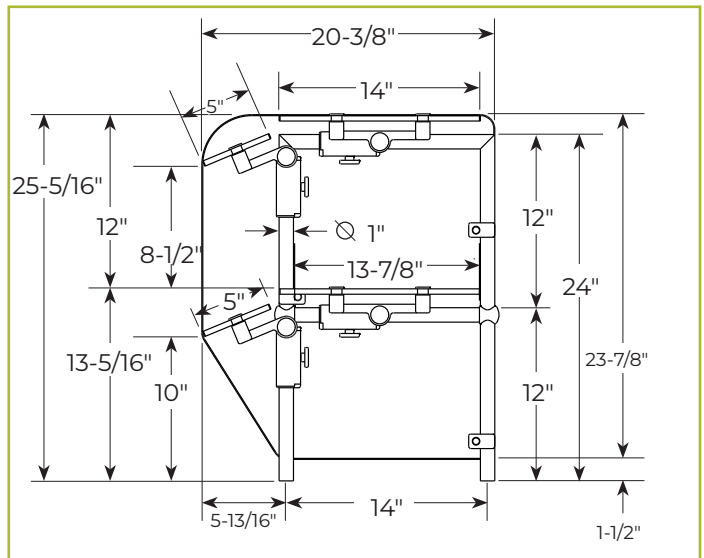

To meet NSF guidelines, end panels are included on all BSI quotations unless specifically excluded. (See End Panel Page for More Details.)

Approval Drawings Required.
Specifications subject to change without notice.



03.25